

Spacemaster® SX1

Electric Wire Rope Hoists

Innovation . . . Performance . . . Reliability

www.meerholz.ca

The ideal hoist for monorails, jibs
and light crane systems



Standard Configurations:

- **1 ton and 2 ton capacities with ASME H4 duty rating**
- **1000 kg and 2000 kg capacities with FEM 2m duty rating**
- **Special low headroom trolley**
- **Two speed hoisting - 1 ton 32/5.3 fpm (9.6/1.6 m/min)**
- 2 ton 16/2.6 fpm (4.8/0.8 m/min)
- **Two speed trolley travel - 78/19.5 fpm (24/6 m/min)**
- **Push button pendant (E-stop, 2H, 2T)**
- **208, 230, 460, 575/3/60 or 380/3/50 power supply**





Spacemaster® SX1 Electric Wire Rope Hoists

Bulletin No. SX1-2006-1
© 2006 R&M Materials Handling, Inc.

Spacemaster® is a registered trademark of R&M Materials Handling, Inc.

- Hoist motor is class F insulated, 60% effective duty and thermally protected
- Near true vertical lift (approx. 1/8" hook drift per foot of lift)
- 40:1 drum to rope diameter ratio extends rope life
- Block actuated upper limit switch
- Lower limit switch
- Mainline contactor
- IP55 / NEMA 4 type control enclosure rating
- Trolley disc brake
- Crown tread trolley wheels
- Trolley bumpers

Model SX1 021

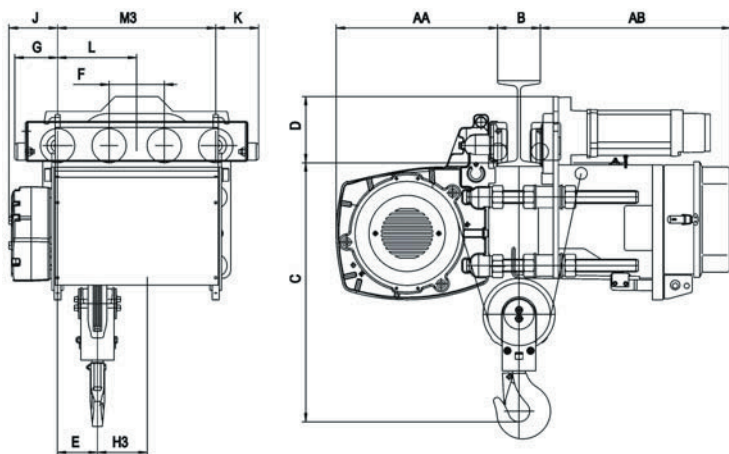

Model SX1 041

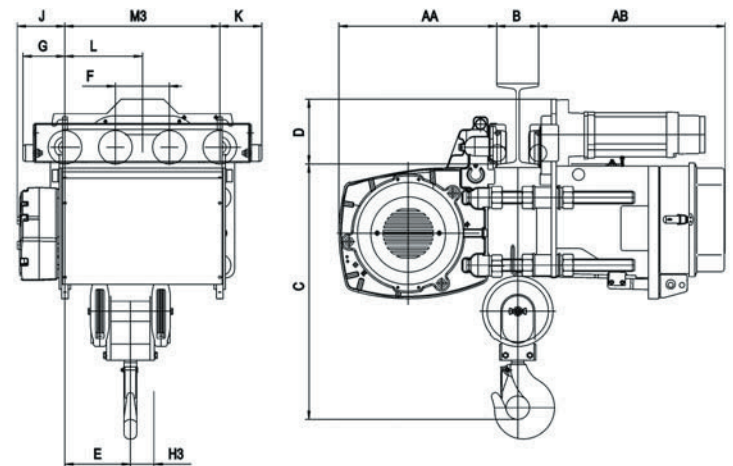

Model / Capacity	Lift Ft.	AA inch	AB inch	B inch	C inch	D inch	E inch	F inch	G inch	H3 inch	J inch	K inch	L inch	M3 inch
SX1 021	19'-8"	14.82	16.3	2.95...11.81	23.82	6.1	3.66	5.07	3.94	2.22	4.47	3.94	7.26	14.5
1 Ton	39'-4"	14.82	16.3	2.95...11.81	23.82	6.1	3.66	5.07	3.94	4.39	4.47	3.94	7.26	14.5
SX1 041	19'-8"	14.82	16.3	2.95...11.81	23.94	6.1	6.14	5.07	3.94	2.2	4.47	3.94	7.26	14.53
2 Ton	29'-6"	14.82	16.3	2.95...11.81	23.94	6.1	6.14	5.07	3.94	3.31	4.47	3.94	7.26	18.86
	m	mm	mm	mm	mm	mm	mm	mm	mm	mm	mm	mm	mm	mm
SX1 021	6	376.5	444	75...300	605	155	93	128.7	100	56.5	113.5	100	184.5	369
1000 kg	12	376.5	444	75...300	605	155	93	128.7	100	111.5	113.5	100	184.5	369
SX1 041	6	376.5	444	75...300	608	155	156	128.7	100	56	113.5	100	184.5	369
2000 kg	9	376.5	444	75...300	608	155	156	128.7	100	84	113.5	100	184.5	479

R&M Materials Handling, Inc. is a proud member of the following organizations:



YOUR DISTRIBUTOR CONTACT IS:



4985 Meadowlark Road, Prince George, BC V2K 5V4
T: [250] 565-8418 E: info@meerholz.ca www.meerholz.ca